



M² Beam

M² laser beam propagation analyzer



- Combines all ISO compliance accuracy
- Flexible, with different versions for pulsed and CW lasers
- Special version for high power measurements up to 4 kWatt
- Removable measuring head for regular laser beam profiling

Specifications

Input Beam

	M2Beam	M2Beam U3
Technology	Multi knife-edge scanning with silicone detector, ingaAs detector and enhanced ingaAs	USB 3 with CMOS 2.4 MP and built in filter wheel
Spectral Range (nm)	350 - 1100 for Si version 800 - 1800 for InGaAs version 190 - 1100 for UV-Enhanced version 800 - 2700 for ingaAs enhanced version	220 - 1350 with built in special CMOS technology
Beam Power Range	100 μ W - 1W (with supplied internal filters for the Si version) 100 μ W - 5 mW for InGaAs & UV versions Up to 4 kW for HP version	10 μ W - 100 mW with built in filter wheel Up to 4 kW for HP version
Number of Knife-edges	7	---
Beam Size	Up to 25mm diameter with lens (Si&UV versions)	
Beam Waist to Lens Distance	2.0 to 2.5 meters optimum 2.0 meters minimum	

Scanning Assembly Attachment

Construction	Aluminium
Lens Focal Length	300 mm (at 632.6 nm)
Lens Diameter	25 mm
Number of Scan Steps	140
Minimum Step Size	100 μ m
Scan Length	280 mm

Physical

Weight	2.5 Kg
Dimensions	100 x 173 x 415 mm
Mounting	M6 or 1/4" screws
Mechanical Adjustment	Horizontal angle: $\pm 1.5^\circ$ Vertical angle: $\pm 1.5^\circ$
Cable Length	2.5 m



M2Beam U3 Version

Accuracy:

M² Values & General Parameters Accuracy: $\pm 5\%$

DUMA OPTRONICS LTD.



海纳光学有限公司
HIGHLIGHT OPTICS CO., LTD.

Tel: 0755-84870203 www.highlightoptics.com

E-mail: sales@highlightoptics.com

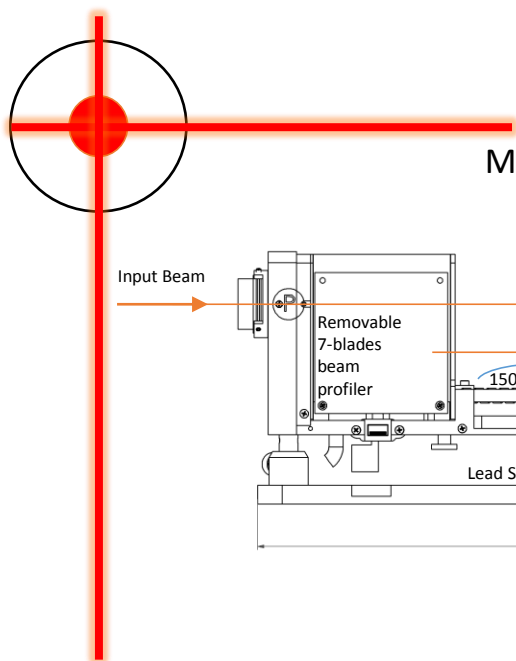

M² Beam

M² laser beam propagation analyzer

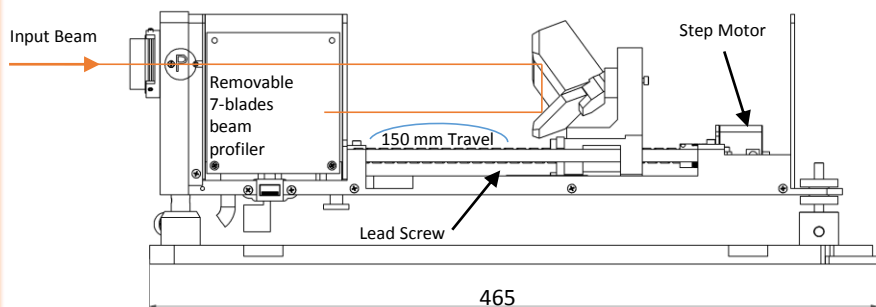

M2Beam

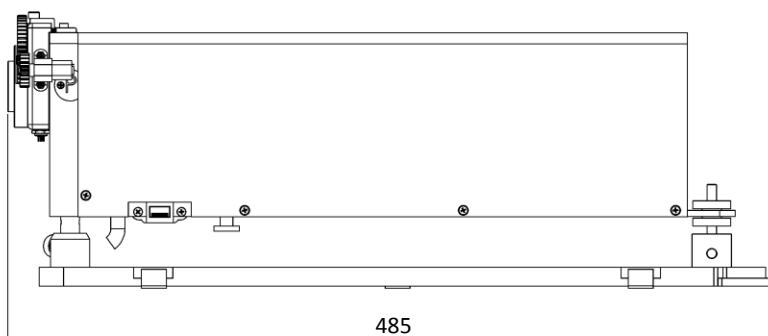
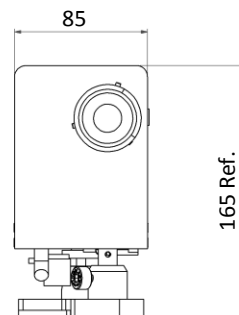

M2Beam U3

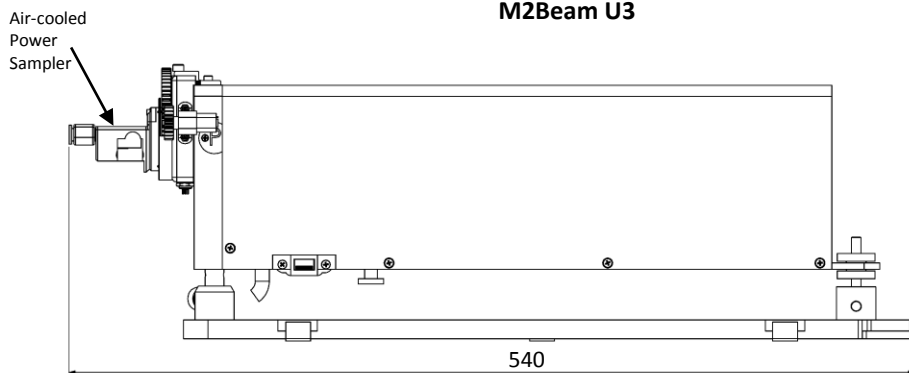
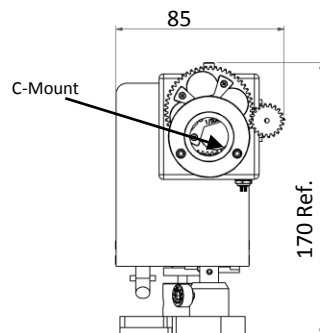

M2Beam U3 High Power

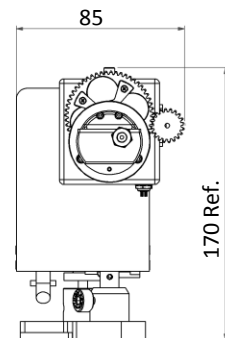

Ordering Information

- M2Beam-Si** – measurement device for silicon range (350 – 1100nm)
- M2Beam-UV** – measurement device for silicon range (190 – 1100nm)
- M2Beam-IR** – measurement device for silicon range (800 – 1800nm)
- M2Beam-U3** - measurement device for 220-1350 nm CMOS based
- SAM3-HP-M** – beam sampler for high power beams

- Measurements:
- Beam Propagation (M²)
 - Beam Waist Location
 - Beam Waist Diameter
 - Divergence
 - Rayleigh Range
 - Waist Asymmetry
 - Astigmatism

DUMA OPTRONICS LTD.



海纳光学有限公司
HIGHLIGHT OPTICS CO., LTD.

Tel: 0755-84870203 www.highlightoptics.com
E-mail: sales@highlightoptics.com

