

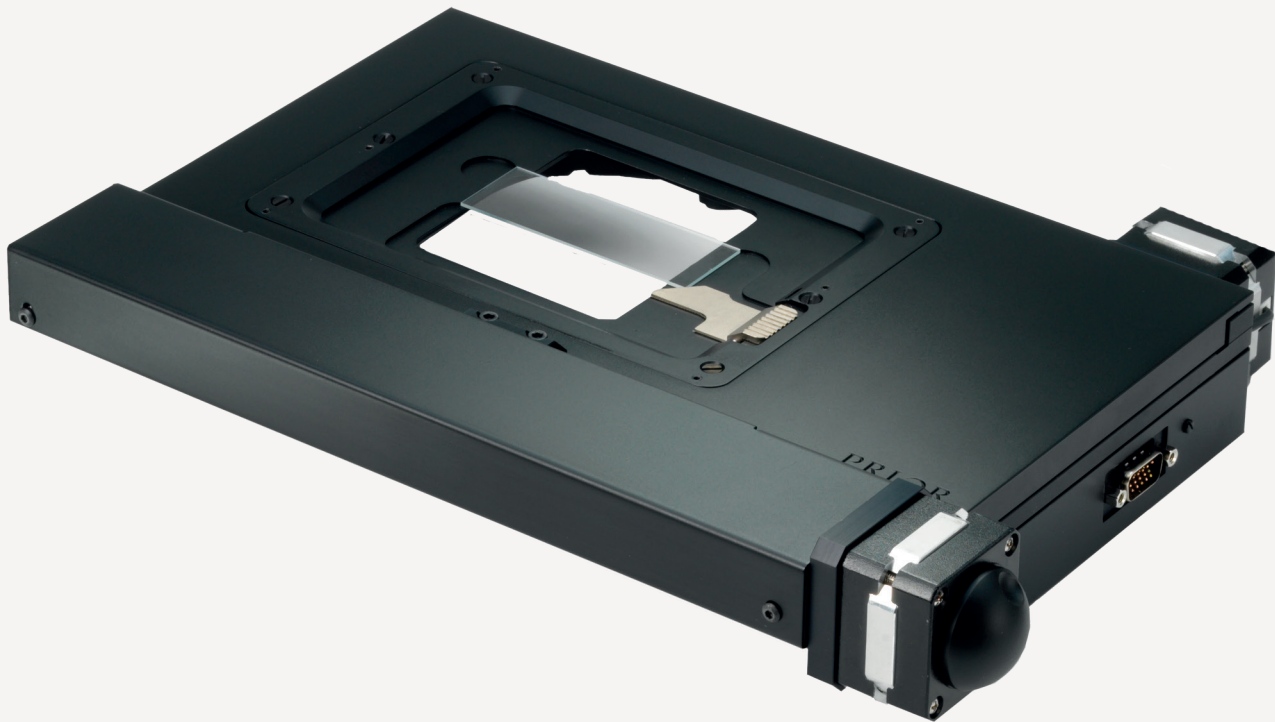

ES111 Stage

Motorised Stage for use with the OptiScan[®] system



Economical yet precise, the ES111 motorised stage is designed to integrate with the OptiScan control system from Prior Scientific and fits with upright microscopes. The ES111 offers excellent control over the XY axes for a reduced outlay compared with other motorised stages on the market; ideal for the user who does not require a sub micrometre repeatability but nevertheless needs a reliable and accurate stage for routine and repetitive imaging applications.

- Step size (resolution) of 1 μm
- Repeatability of $\pm 5 \mu\text{m}$
- Travel range 125 x 75 mm.
- Compatible with the full range of Prior specimen holders, including standard slide holders, multi-well plate holders, Petri dish holders and metallurgical specimen holders
- The unique S curve acceleration algorithm allows fast, smooth positioning without vibration, reducing disruption to samples.
- Anti-backlash precision lead screws
- Adjustable XY limit switches

ES111Stage

Motorised Stage for the OptiScan System

Dimensions

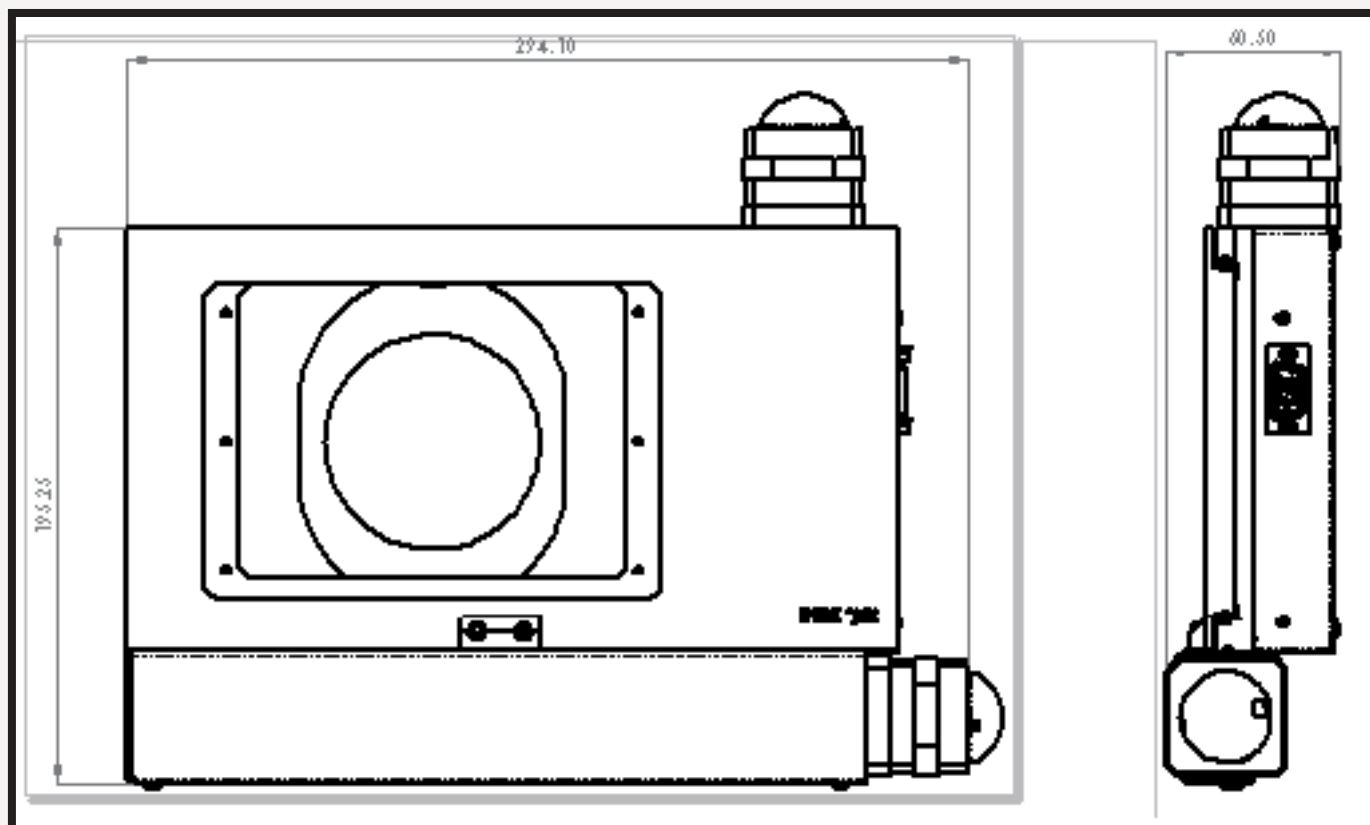

Specifications*

Feature	Specification
Travel Range:	Upright - 125 x 75 mm
Repeatability:	± 5 µm
Step size (Resolution):	1 µm
Linear Slides:	3 mm ball bearings
Drive mechanism:	Anti-backlash precision lead screw
Limit Switches:	X and Y standard, adjustable.

* All specifications are based on the Prior method of testing and are only valid with a Prior controller



Prior Scientific Ltd

3-4 Fielding Industrial Estate • Wilbraham Road • Fulbourn • Cambridge • CB21 5ET • UK

t: +44 (0)1223 881711 • e: uksales@prior.com • www.prior-scientific.co.uk



FM 61600



Prior Scientific Inc

80 Reservoir Park Drive • Rockland • MA. 02370 • U.S.A.

t: +1 781-878-8442 • e: info@prior.com • www.prior-us.com

Registered Address: Units 3/4 Fielding Industrial Estate • Wilbraham Road • Fulbourn • Cambridge • CB21 5ET • United Kingdom Registered in England 404087

