

BeamOn U3 High Power

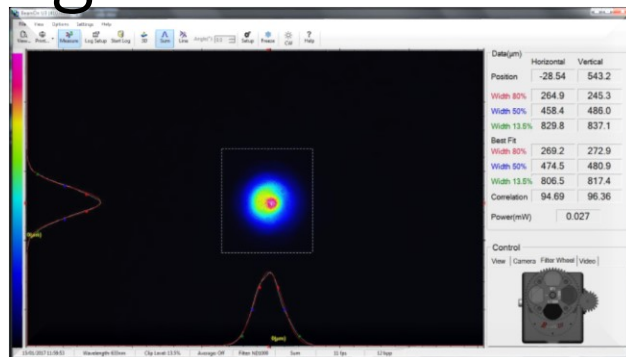

USB 3.0



Integrated Filter Wheel

Advanced software features

Innovative High Power Beam Profiler (1/1.2") based on advanced beam sampling in conjunction with high resolution camera

Measurement capability of a few kWatts laser power

Versatile – Measures **Profile, Power and Position**

Specifications

Beam Size Range	ø100 µm - ø6 mm	Pixel Size	5.86 µm x 5.86 µm
Spectral Response	350 – 1310 nm	Frame Rate	40 fps (8 bit)
Power Range @900/1070	CW 1-2500 W, Pulsed 1 – 1000 W	Sensor Active Area (mm)	11.34 x 7.13
Maximum Power Density	100,000 W/cm ² (contact factory)	Interface	USB 3.0, windows XP/7/8/10 (32 & 64 bit)
Emerging Power towards Beam Dump	90% of input power	Pixel Bit Depth	8/12 bits
Power Measuring	After user's calibration	Synchronization	•Software •Hardware (external trigger signal)
Gain Control	1 -24 dB	Exposure Control	Programmable via GUI
Dynamic Range	60 dB not including filters	Housing Size (L x W x H) in mm	64 x 103 x 73.5
Shutter Speed	39 µsec to 20 sec	Power Requirements	~2 Watt (Via USB 3.0 interface)
Built-in Automatic Filter Wheel with 3 Filters:	-Unpopulated -ND8 -ND200 -ND1000	Weight (typical)	350 gr.
Working Distance	49 mm (contact factory)	Mechanical Interface	Post mounting: 2 concentric opposite 8-32 UNC, 6 mm depth
Maximum BPP	Max. input angle – 25 deg.	Cooling Conditions	Pressurized air of 6-8 Bar
Resolution (H x V pixels)	1920 x 1200	Operating Temperature	0° – 35° C

Ordering Information

Model BeamOn U3HP- VIS NIR: A camera for 350 – 1310 nm with motorized built-in filter wheel with a set of 3xND filters (ND8, ND200, and ND1000) in housing, USB3.0 cable, software and user manual on CD/Disk on key, carrying case.

DUMA OPTRONICS LTD.

Website: <http://www.dumaoptronics.com>

E-mail: sales@duma.co.il

July 2018

BeamOn U3 High Power

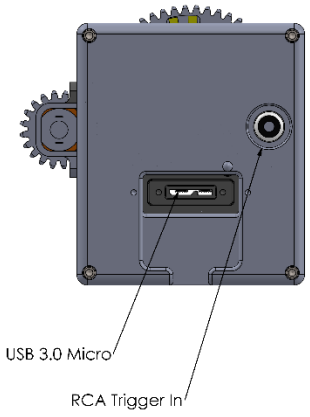
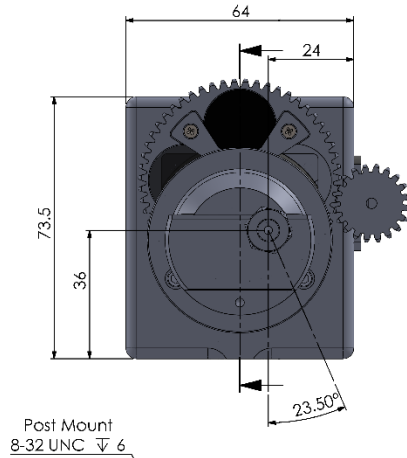
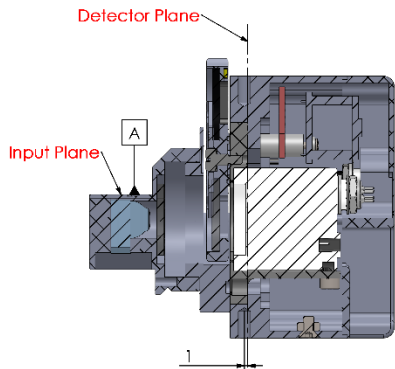

Optical distance from Input plane A to Detector Plane: 49 ± 0.5

Warning: For Focused beams, Focal Point must be at least 30 mm after input plane A (towards the sensor).

Focusing on input optics will damage the optical system!

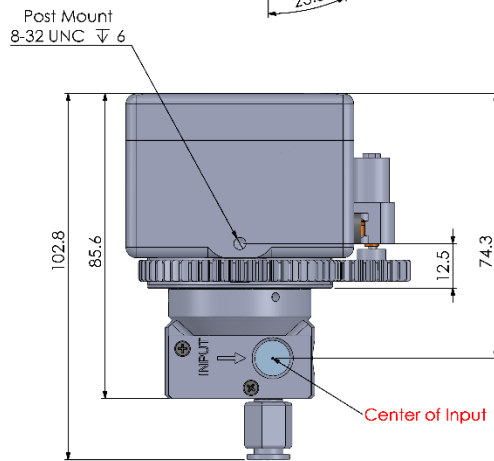

Dimensions are in mm.

DUMA OPTRONICS LTD.

Website: <http://www.dumaoptronics.com>

E-mail: sales@duma.co.il

July 2018

